



SolarStop

A freestanding solar powered transit shelter with integrated lighting, wireless mobile device charging and backlit signage

FEATURES & BENEFITS

FREESTANDING STRUCTURE

- No foundations required
- No underground electrical
- Weatherproof

ALUMINUM CONSTRUCTION

- Ultra durable
- Corrosion resistant
- Ease of installation

INTEGRATED OFF GRID POWER SYSTEM

- Programmable lighting
- Wireless mobile charging

OPTIONS

- Double sided backlit lightbox
- Backlit map sign
- Wifi hot spot integration



DIMENSIONS

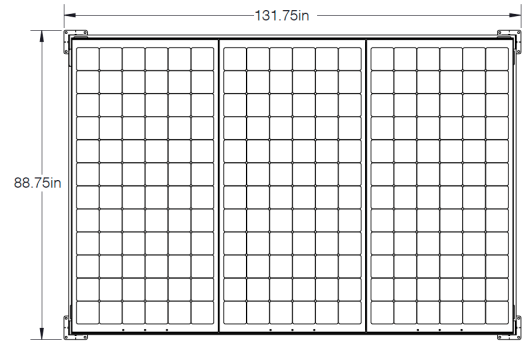
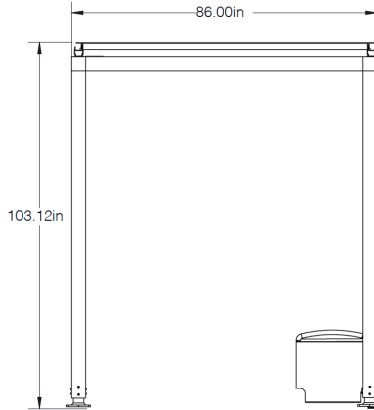
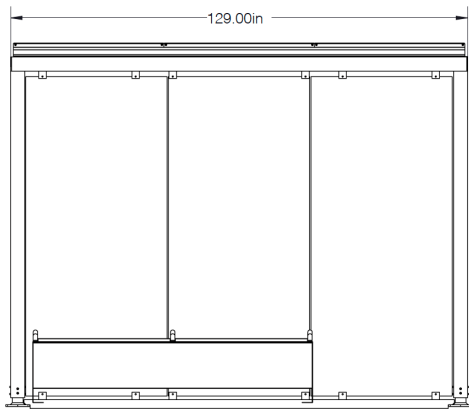

SLAB RECOMMENDATIONS

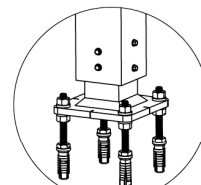
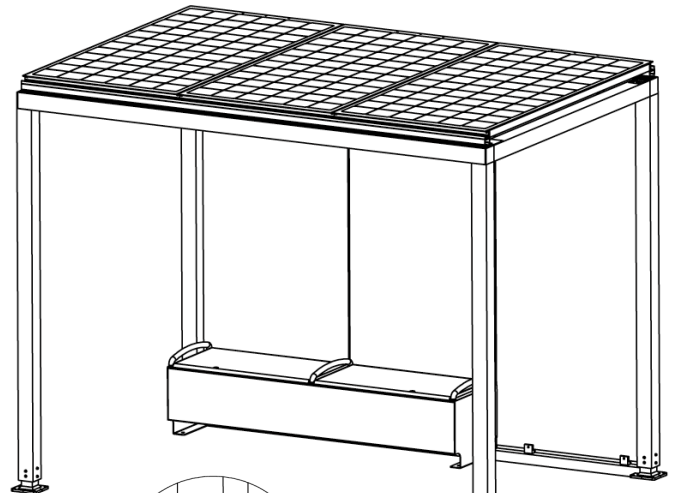
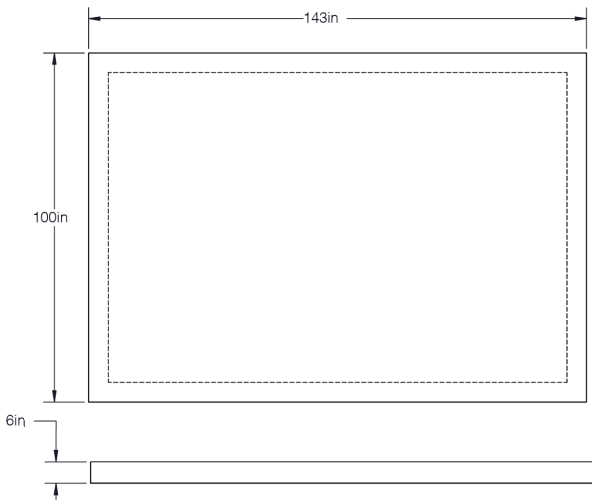

DETAIL A



Made in the USA