

# GSX Module System BIF

A weatherproof bifacial module system ideal for use in overhead applications

## FEATURES & BENEFITS

---

### INFINITY EDGE GLASS™

- PID free
- Continuous glass surface

### GLASS GLASS CONSTRUCTION

- Ultra durable
- Maximum efficiency



### INTEGRATED MOUNTING SYSTEM

- Built in wireway
- Concealed junction boxes and conductors
- Can be weatherproofed

The GSX Module System offers system designers unparalleled freedom to meet their power and light transmittance requirements with an off the shelf system. With two primary footprints, and ten different cell configurations, almost any design can be accommodated.

## ELECTRICAL SPECIFICATIONS

Model	GSX 72/72	GSX 72/60	GSX 72/40	GSX 72/32	GSX 72/0	GSX 60/60	GSX 60/48	GSX 60/32	GSX 60/24	GSX 60/0
<b>Rated Power @ STC (front side)</b>	<b>370 W</b>	<b>308 W</b>	<b>206 W</b>	<b>164 W</b>	<b>0</b>	<b>308 W</b>	<b>247 W</b>	<b>164 W</b>	<b>123 W</b>	<b>0</b>
Peak Power Voltage (Vmp)	38.6 V	32.2 V	21.5 V	17.2 V	0	32.2 V	25.8 V	17.2 V	12.9 V	0
Maximum Power Current (Imp)	9.6 A	9.6 A	9.6 A	9.6 A	0	9.6 A	9.6 A	9.6 A	9.6 A	0
Open Circuit Voltage (Voc)	47.6 V	39.6 V	26.4 V	21.1 V	0	39.6 V	31.7 V	21.1 V	15.9 V	0
Short Circuit Current (Isc)	10.56 A	10.54 A	10.54 A	10.54 A	0	10.54 A	10.54 A	10.54 A	10.54 A	0
Module Efficiency	18.4%	15.3%	10.2%	8.2%	0	18.1%	14.5%	9.7%	7.3%	0
<b>+10% BiFi Boost (back side)</b>	<b>407 W</b>	<b>339 W</b>	<b>226 W</b>	<b>181 W</b>	<b>0</b>	<b>339 W</b>	<b>271 W</b>	<b>181 W</b>	<b>136 W</b>	<b>0</b>
Peak Power Voltage (Vmp)	38.6 V	32.2 V	21.5 V	17.2 V	0	32.2 V	25.8 V	17.2 V	12.9 V	0
Maximum Power Current (Imp)	10.54 A	10.54 A	10.54 A	10.54 A	0	10.54 A	10.54 A	10.54 A	10.54 A	0
Open Circuit Voltage (Voc)	47.6 V	39.6 V	26.4 V	21.1 V	0	39.6 V	31.7 V	21.1 V	15.9 V	0
Short Circuit Current (Isc)	11.30 A	11.30 A	11.30 A	11.30 A	0	11.30 A	11.30 A	11.30 A	11.30 A	0
Module Efficiency	20.2%	16.9%	11.2%	9.0%	0	20.0%	16.0%	10.6%	8.0%	0
<b>+20% BiFi Boost (back side)</b>	<b>444 W</b>	<b>370 W</b>	<b>247 W</b>	<b>197 W</b>	<b>0</b>	<b>370 W</b>	<b>296 W</b>	<b>197 W</b>	<b>148 W</b>	<b>0</b>
Peak Power Voltage (Vmp)	38.7 V	32.3 V	21.5 V	17.2 V	0	32.3 V	25.8 V	17.2 V	12.9 V	0
Maximum Power Current (Imp)	11.47 A	11.47 A	11.47 A	11.47 A	0	11.47 A	11.47 A	11.47 A	11.47 A	0
Open Circuit Voltage (Voc)	47.7 V	39.8 V	26.5 V	21.2 V	0	39.8 V	31.8 V	21.2 V	15.9 V	0
Short Circuit Current (Isc)	12.29 A	12.29 A	12.29 A	12.29 A	0	12.29 A	12.29 A	12.29 A	12.29 A	0
Module Efficiency	22.1%	18.49%	12.39%	9.8%	0	21.8%	17.4%	11.6%	8.7%	0
<b>+30% BiFi Boost (back side)</b>	<b>481 W</b>	<b>401 W</b>	<b>267 W</b>	<b>214 W</b>	<b>0</b>	<b>401 W</b>	<b>321 W</b>	<b>214 W</b>	<b>160 W</b>	<b>0</b>
Peak Power Voltage (Vmp)	38.7 V	32.3 V	21.5 V	17.2 V	0	32.3 V	25.8 V	17.2 V	12.9 V	0
Maximum Power Current (Imp)	12.09 A	12.09 A	12.09 A	12.09 A	0	12.09 A	12.09 A	12.09 A	12.09 A	0
Open Circuit Voltage (Voc)	47.7 V	39.8 V	26.5 V	21.2 V	0	39.8 V	31.8 V	21.2 V	15.9 V	0
Short Circuit Current (Isc)	13.31 A	13.31 A	13.31 A	13.31 A	0	13.31 A	13.31 A	13.31 A	13.31 A	0
Module Efficiency	23.9%	19.9%	13.3%	10.6%	0	23.6%	18.9%	12.6%	9.4%	0

Operating Temperature	-40 °C to 85 °C									
Maximum System Voltage	1000 V									
Maximum Series Fuse Rating	15 A									
Power Tolerance	-0/+3%									
Solar Cell	Monocrystalline Bifacial 6" x 6" (156 mm x 156 mm)									
Number of Cells	72 (6x12)	60 (6x10)	40 (4x10)	32 (4x8)	0	60 (6x10)	48 (6x8)	32 (4x8)	24 (4x6)	0
Module Dimensions	79.17 in x 39.4 in x 0.3 in (2011 mm x 1000 mm x 8 mm)					66.92 in x 39.4 in x 0.3 in (1700 mm x 1000 mm x 8 mm)				
Module Area	21.7 ft <sup>2</sup> (2.01m <sup>2</sup> )					18.3 ft <sup>2</sup> (1.7m <sup>2</sup> )				
Front/ Back Glass	Tempered Low-Iron PV Glass									
Module Weight	70.1 lbs (31.8 kg)					59.25 lbs (26.88 kg)				
System Weight / Area	3.88 psf (18.94 kg/m <sup>2</sup> )					3.88 psf (18.94 kg/m <sup>2</sup> )				
Static Load	GSX60__ +98 psf/ -82 psf GSX72__ +65 psf/ -65 psf GSX72__HS +81 psf/ -82 psf									
Output Cables	12 Awg. PV Wire and MC4 Compatible Connectors									
Fire Rating	Class A									
Certifications	 UL1703  UL2703									
Warranty	10 years Workmanship / 30 years Linear Power Production (Power Production Warranty on Front Side STC Only)									

## TEMPERATURE COEFFICIENTS

Nominal Operating Cell Temperature (NOCT)	43.6 °C
Power Temperature Coefficient (Pmpp)	-0.453 % / °C
Voltage Temperature Coefficient (Voc)	-0.337 % / °C
Current Temperature Coefficient (Isc)	0.054 % / °C

Lumos Solar © 2021 Specifications are subject to change without notice. Version 2021-1

## MODULE CONFIGURATIONS

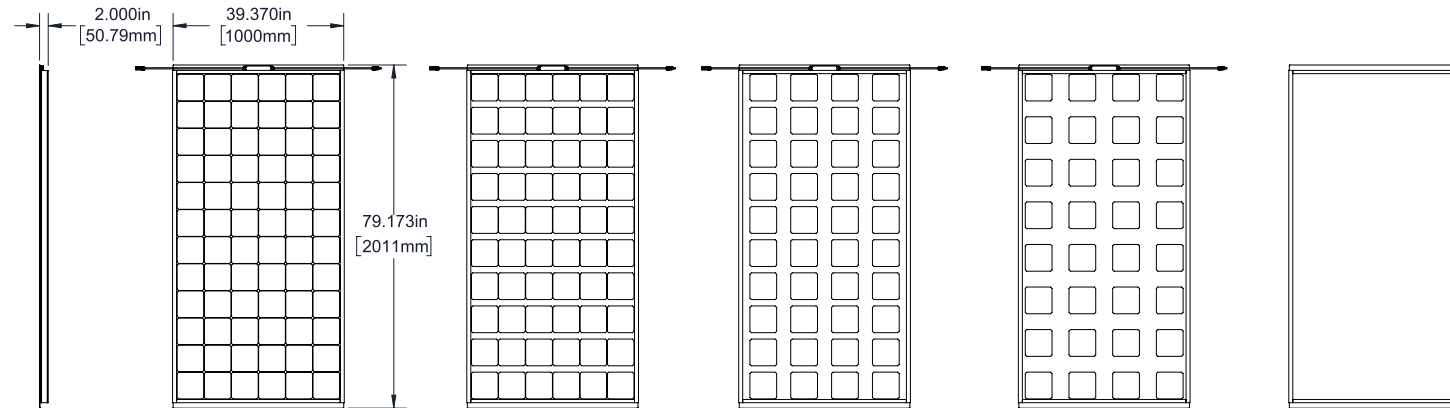

Model	GSX 72/72	GSX 72/60	GSX 72/40	GSX 72/32	GSX 72/0
Estimated Power Output	407 W	339 W	226 W	181 W	0 W
Light Transmittance	4%	20%	47%	57%	95%

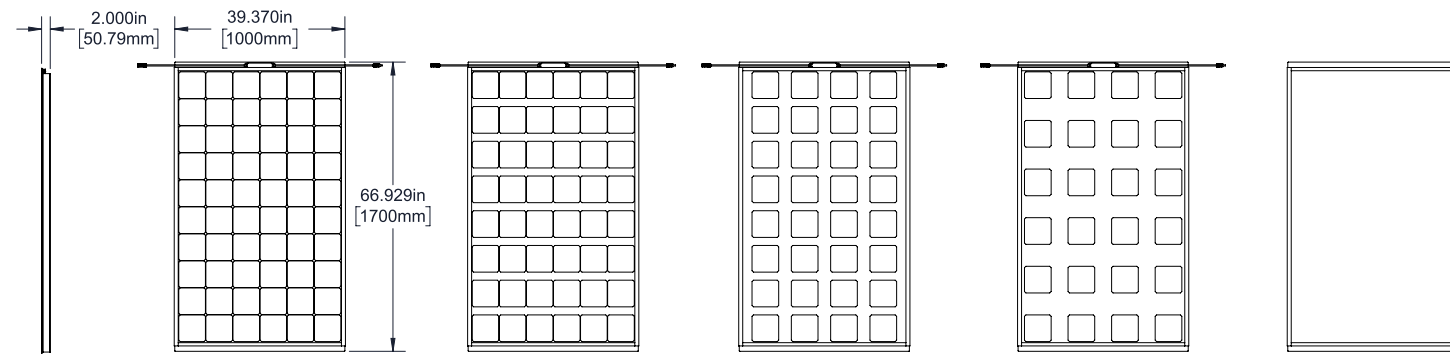

Model	GSX 60/60	GSX 60/48	GSX 60/32	GSX 60/24	GSX 60/0
Estimated Power Output	339 W	271 W	181 W	136 W	0 W
Light Transmittance	4%	24%	49%	62%	95%

- Estimated Power Output is Rated Power at STC (front side) plus 10% BiFi Boost (back side)
- Light Transmittance is calculated based on cell coverage and not a result of testing

## MOUNTING SYSTEM

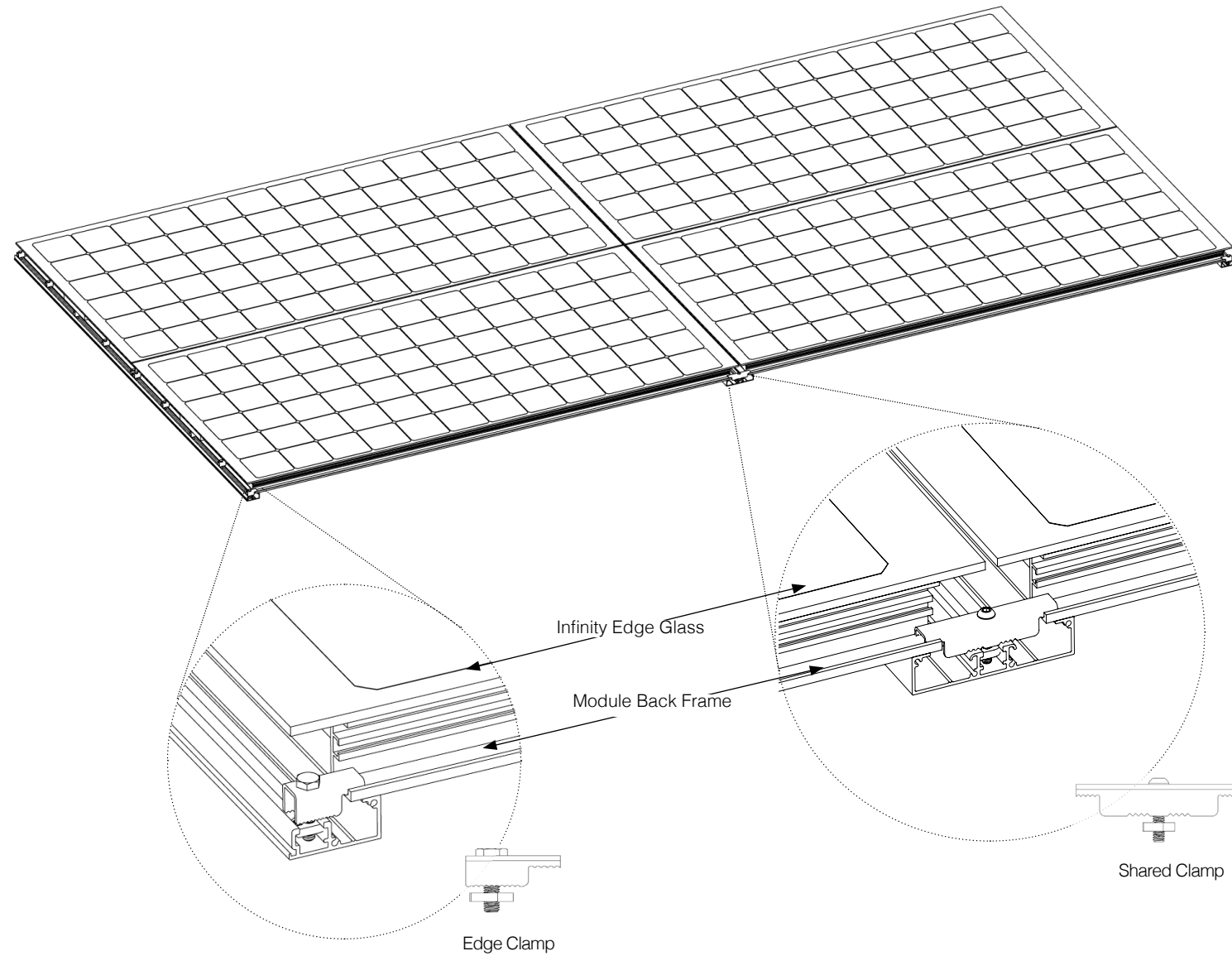

## GSX RAIL LENGTHS

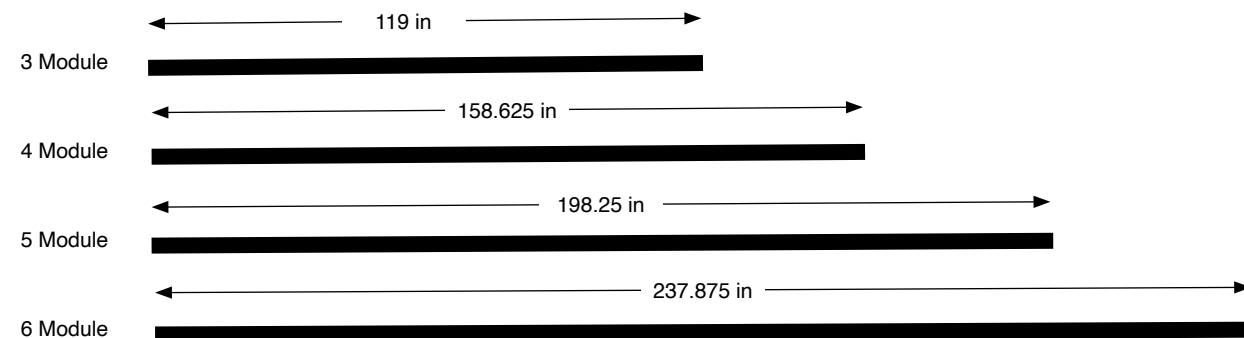

## GSX RAIL OPTIONS

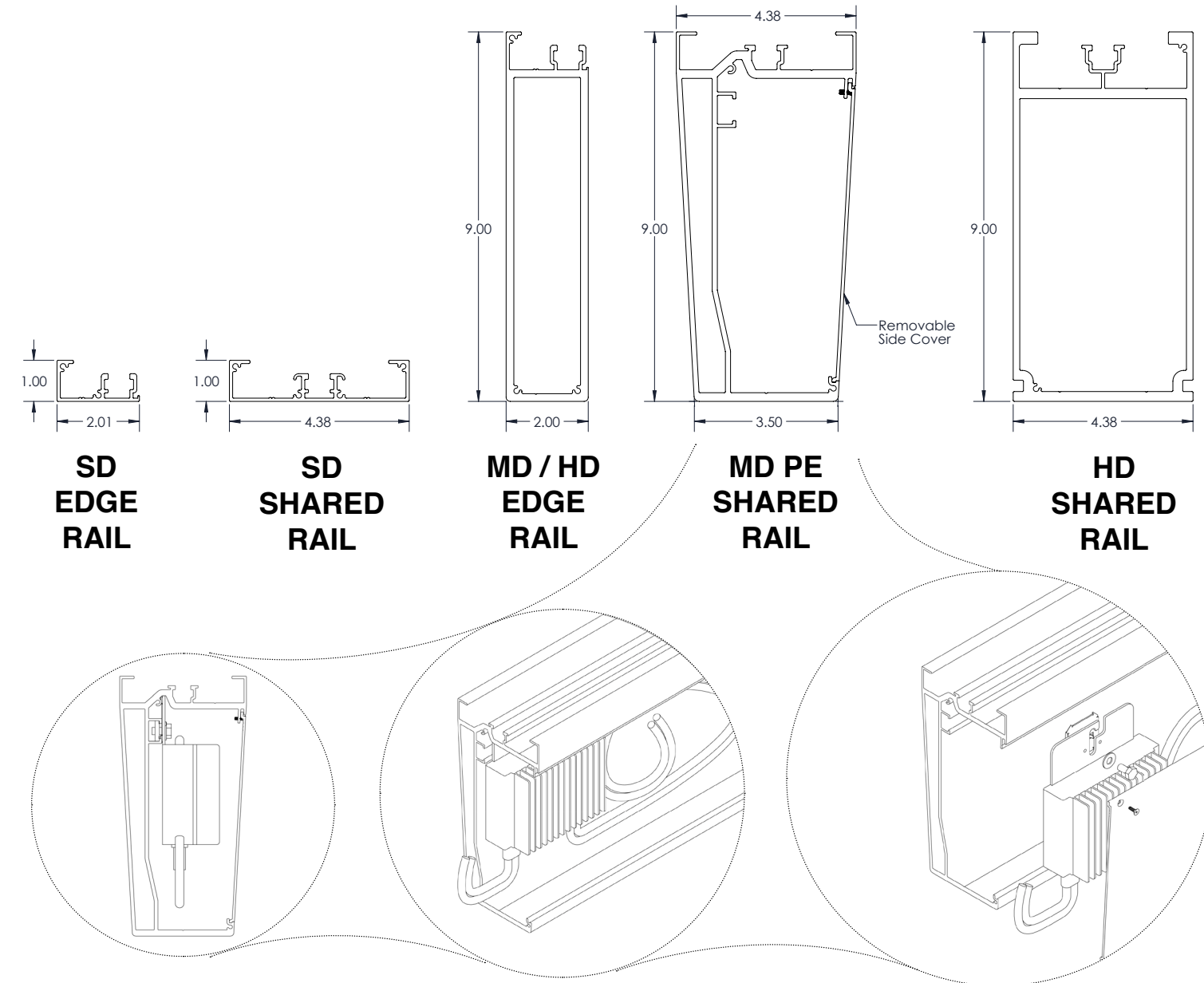

## GSX RAIL SPANS\*

	Wind Speed (mph)	Snow Load (psf)	SD EDGE RAIL Max Span (ft)	SD SHARED RAIL Max Span (ft)	MD / HD EDGE RAIL Max Span (ft)	MD PE SHARED RAIL Max Span (ft)	HD SHARED RAIL Max Span (ft)
Honolulu	110	0	2' 5"	2' 7"	21' 4"	7' 7"	21' 0"
Los Angeles	110	0	2' 5"	2' 5"	21' 4"	7' 7"	21' 0"
Atlanta	115	5	2' 4"	2' 6"	21' 4"	7' 7"	21' 0"
Denver	110	20	2' 2"	2' 4"	19' 7"	6' 11"	19' 4"
Miami	180	0	1' 10"	1' 11"	18' 0"	6' 5"	17' 9"

\*Assumes multiple span condition. Additional site factors outside the scope of this chart can increase or decrease the allowable span.

